

Q 9

Western Horsemanship Amateur 3/4

Show Date: 02. - 11.10.2009

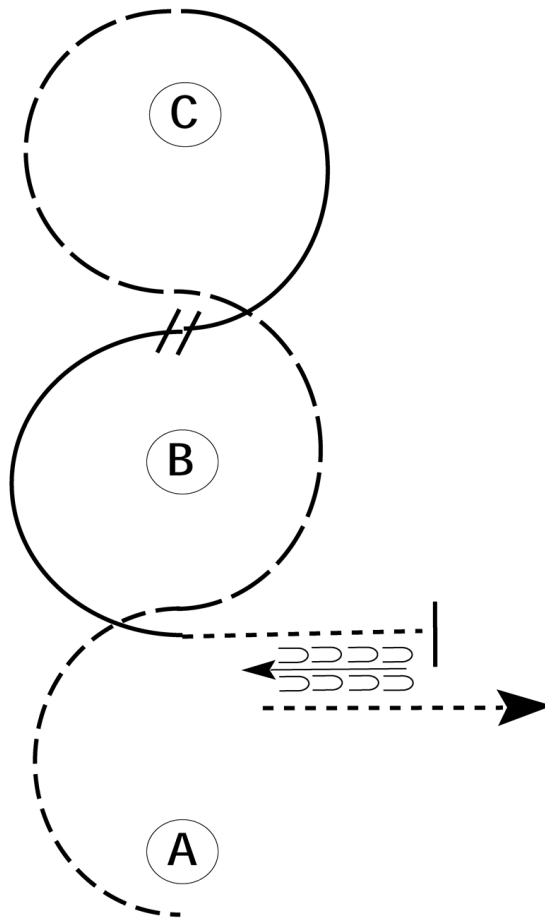

Be ready at A.

1. Jog in a half circle until between A and B.
2. Extend the jog around B and C as shown.
3. Lope on the right lead in a half circle until between C and B.
4. Perform a simple lead change.
5. Lope on the left lead in a half circle until between B and A.
6. Walk approximately 2 horse lengths.
7. Stop and back approximately one horse length then walk straight away.

Follow the instructions of your ring steward.

Walk	-----
Jog	- - - - -
Extended Jog	- - - - -
Lope	—————
Lead Change	———/———
Back	←——— ←———
Marker	ⓑ

[WH/2-85]

Pattern Provided by:

DQHA

Q9

Western Horsemanship Amateur 1/2

Show Date: 02. - 11.10.2009

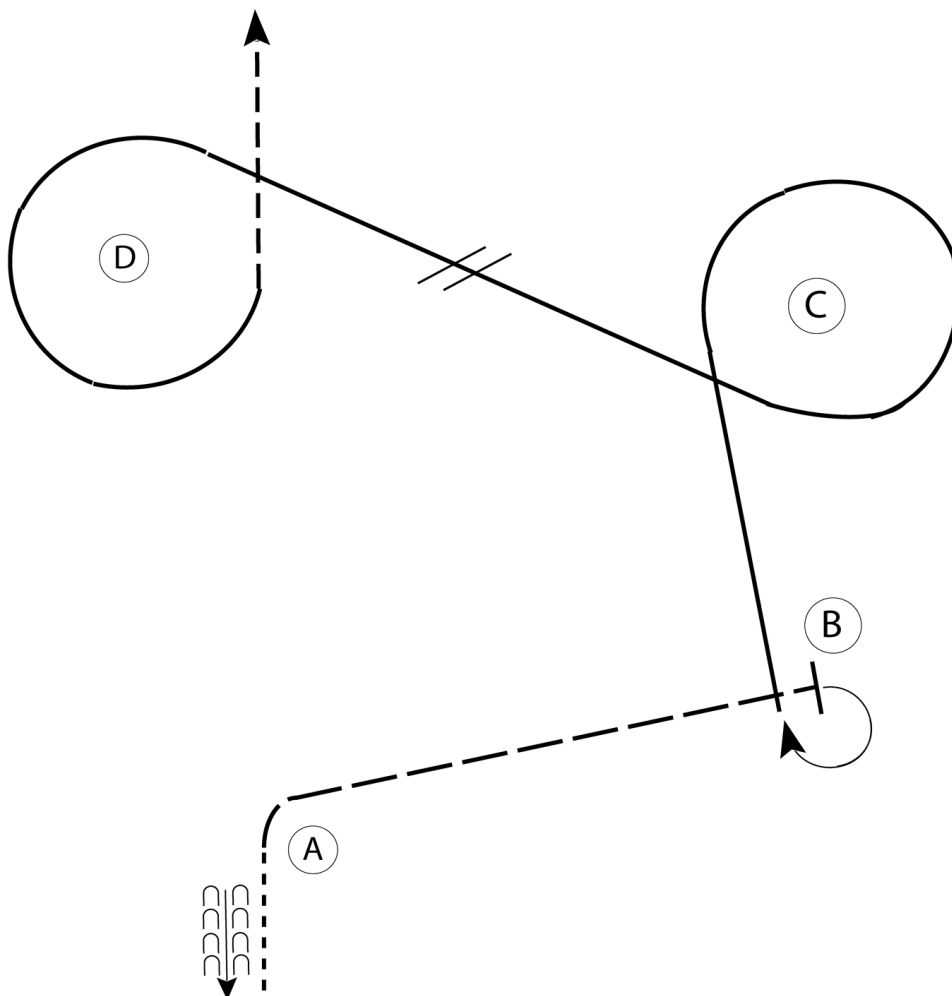

1. Begin before A. Back one horse length
2. Walk to A. Extend the jog to B
3. At B stop. Perform a 270 degree turn on the hindquarters to the right
4. Lope on the right lead around C
5. Perform a simple or flying change of lead between C and D
6. Lope on the left lead around D
7. Break to the jog at D
8. Jog to the exit

Walk
Jog	-----
Extended Jog	-----
Lope	—————
Leg Yield	
Lead Change	///
Back	←←←←
Marker	(B)
Sidepass	←-----→

[WH/2-57]

Pattern Provided by:

DQHA

Q9

Hunter Hack 3/4 all classes

Show Date: 02. - 11.10.2009

www.HorseShowPatterns.com

www.HorseShowPatterns.com

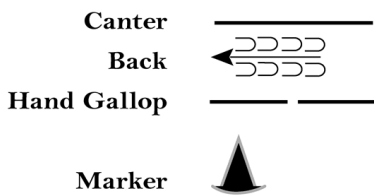
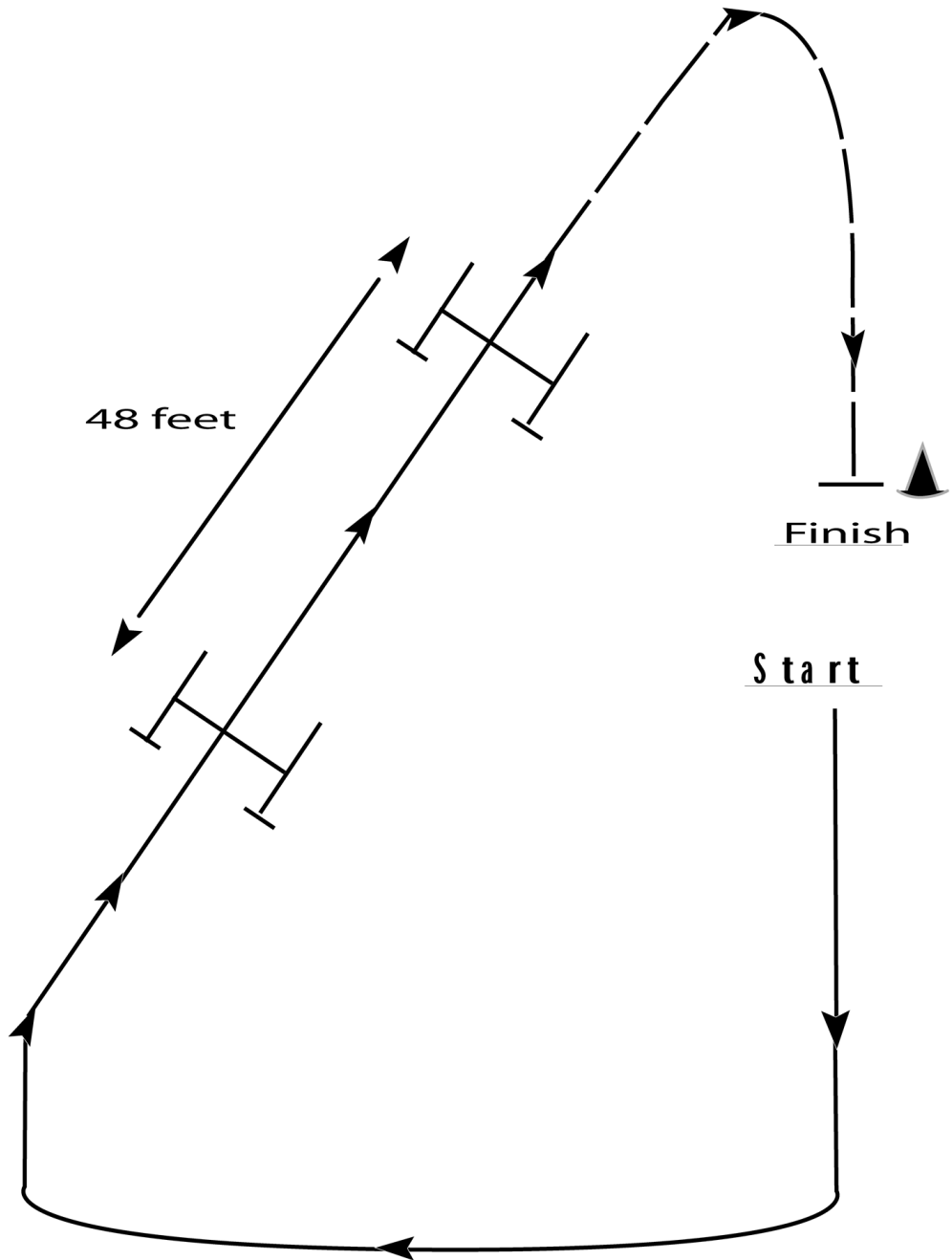

1. Fences are set approximately 48 feet apart.
2. After 2nd fence, hand gallop to marker and stop.
3. Drop your reins to signify completion.

[HH/48-9]

Pattern Provided by:

DQHA

Q9

Hunter Hack 1/2 all classes

Show Date: 02. - 11.10.2009

w w w . H o r s e S h o w P a t t e r n s . c o m

w w w . H o r s e S h o w P a t t e r n s . c o m

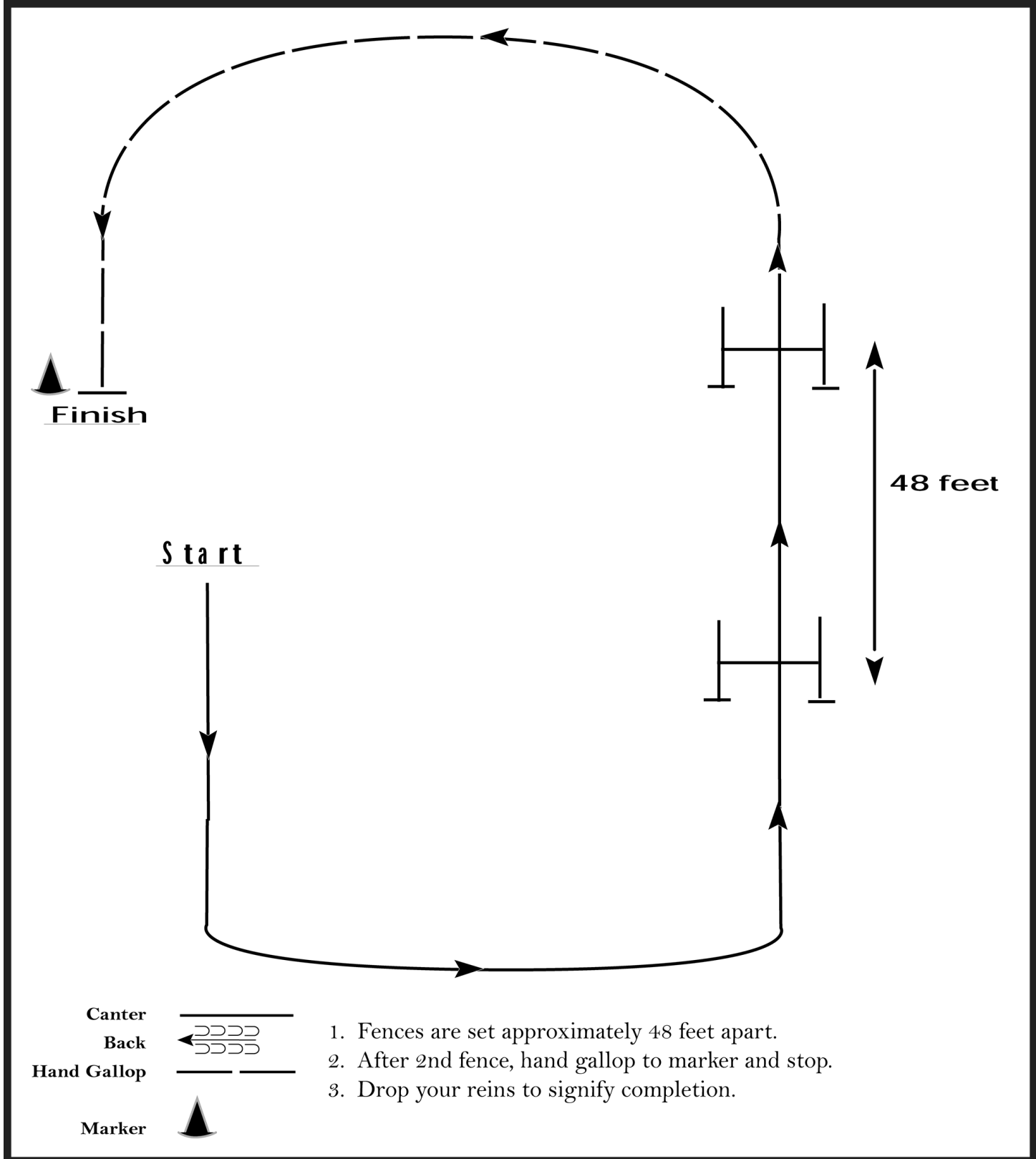

[HH/48-5]

Pattern Provided by:
DQHA

Q9

Western Horsemanship Select

Show Date: 02. - 11.10.2009

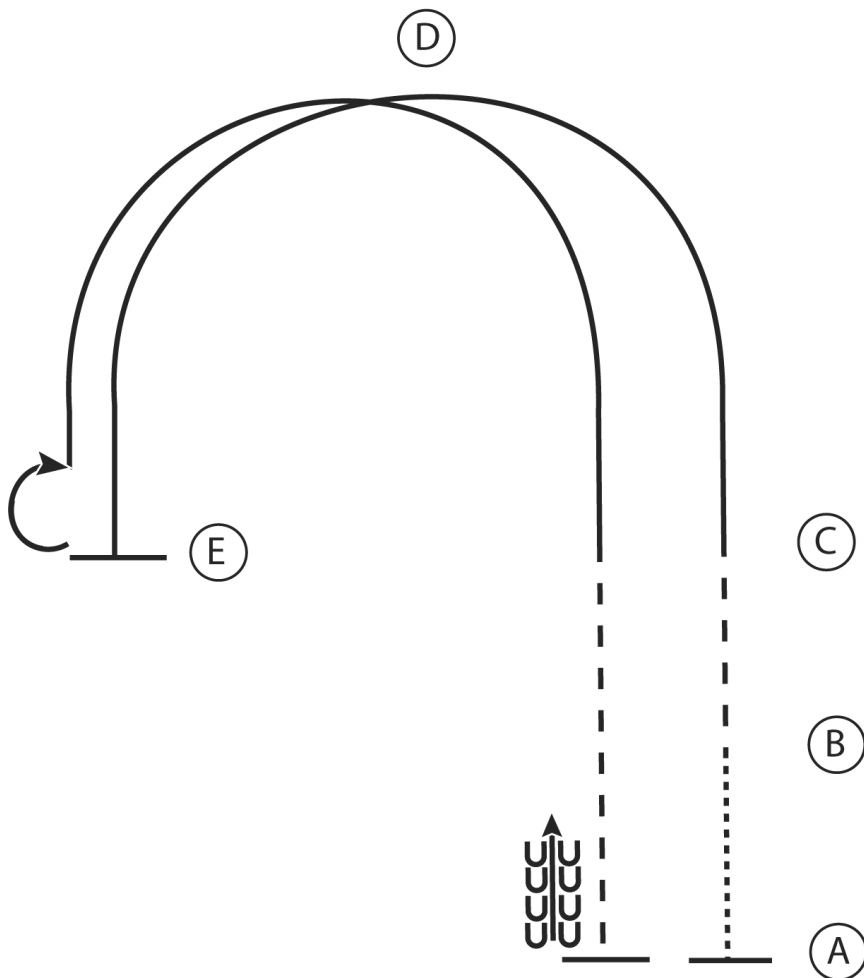

1. Walk A to B
2. At B jog to C
3. At C lope on the left lead in a half circle to E
4. Stop at E and perform a 180 degree turn to the right
5. Lope on the right lead in a half circle to C
6. At C jog to A
7. At A stop and back 4 steps

Walk
Jog	-----
Extended Jog	- - - - -
Lope	—————
Leg Yield	
Lead Change	///
Back	←←←←
Marker	(B)
Sidepass	←- - - -→

[WH/2-28]

Pattern Provided by:

DQHA

Q9

Hunt Seat Equitation Novice Youth

Show Date: 02. - 11.10.2009

w w w . H o r s e S h o w P a t t e r n s . c o m

w w w . H o r s e S h o w P a t t e r n s . c o m

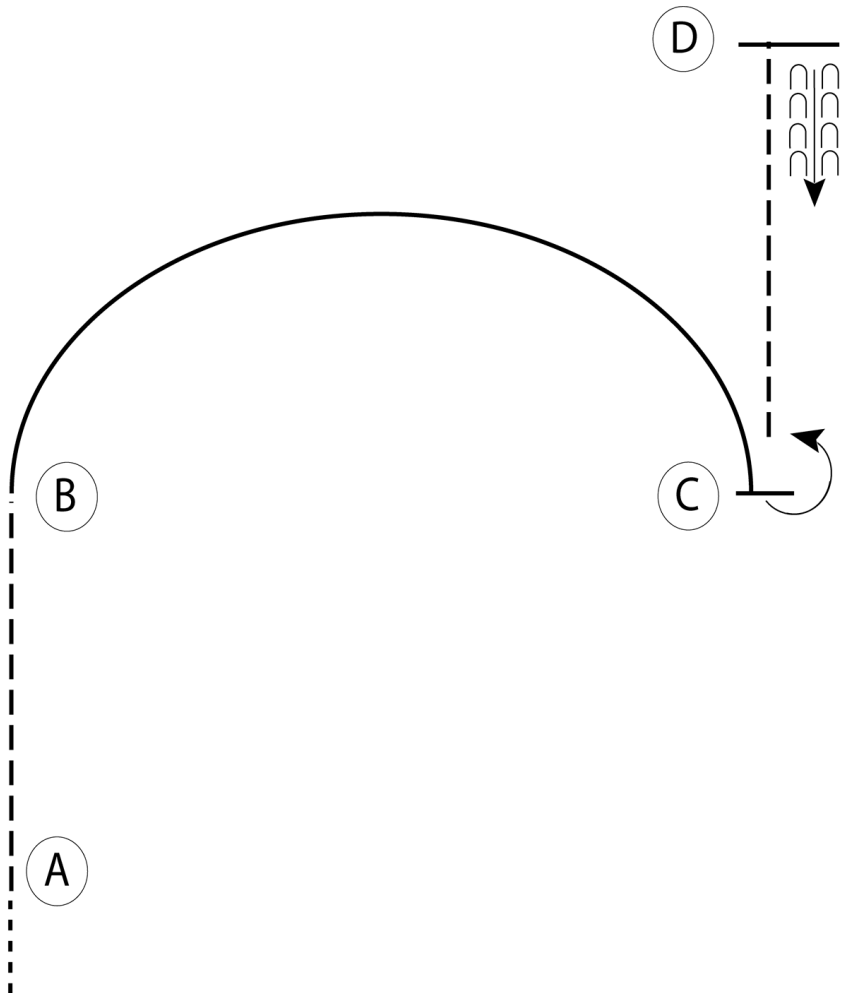

Be ready before A.

1. Walk to A.
2. Posting trot on the right diagonal from A to B.
3. Canter on the right lead from B to C.
4. At C stop and perform a 180 degree turn on the forehand to the left.
5. Posting trot on the left diagonal to D.
6. At D, stop and back approximately one horse length.

Follow the instructions of your ring steward.

Walk
Trot	- - - - -
Extended Trot	- - - - -
Canter	—————
Leg Yield	
Lead Change	///
Back	←←←
Marker	(B)
Sidepass	←- - - ->
Hand Gallop	—————

[HSE/1-31]

Pattern Provided by:

DQHA

Q9

Hunt Seat Equitation Novice Amateur

Show Date: 02. - 11.10.2009

w w w . H o r s e S h o w P a t t e r n s . c o m

w w w . H o r s e S h o w P a t t e r n s . c o m

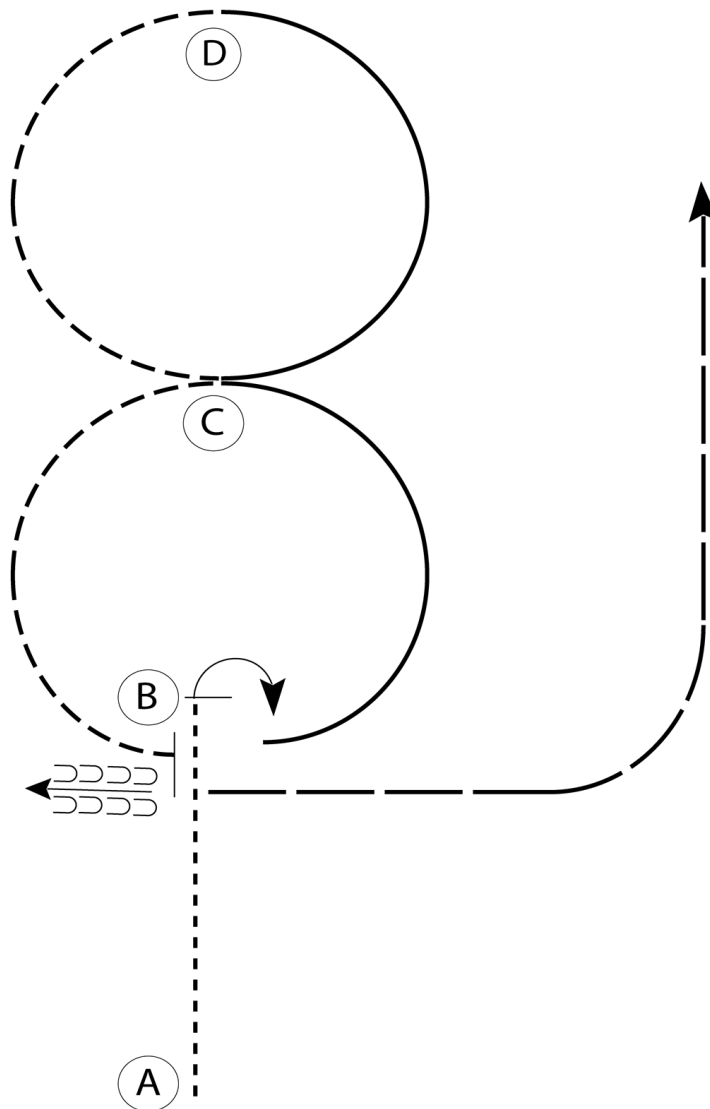

1. Walk from A to B
2. At B stop and perform a 90 turn on the forehand to the right
3. Canter on the left lead to C
4. Posting trot from C to D
5. At D canter on the right lead to C
6. Posting trot from C to B
7. At B stop and back one horse length
8. Hand gallop to the exit

Walk	-----
Trot	- - - - -
Extended Trot	— — — — —
Canter	—————
Leg Yield	
Lead Change	— / —
Back	← ← ← ← ←
Marker	(B)
Sidepass	← — — — — →
Hand Gallop	— — — — —

[HSE/1-26]

Pattern Provided by:

DQHA

Q 9

Hunt Seat Equitation Amateur 1/2

Show Date: 02. - 11.10.2009

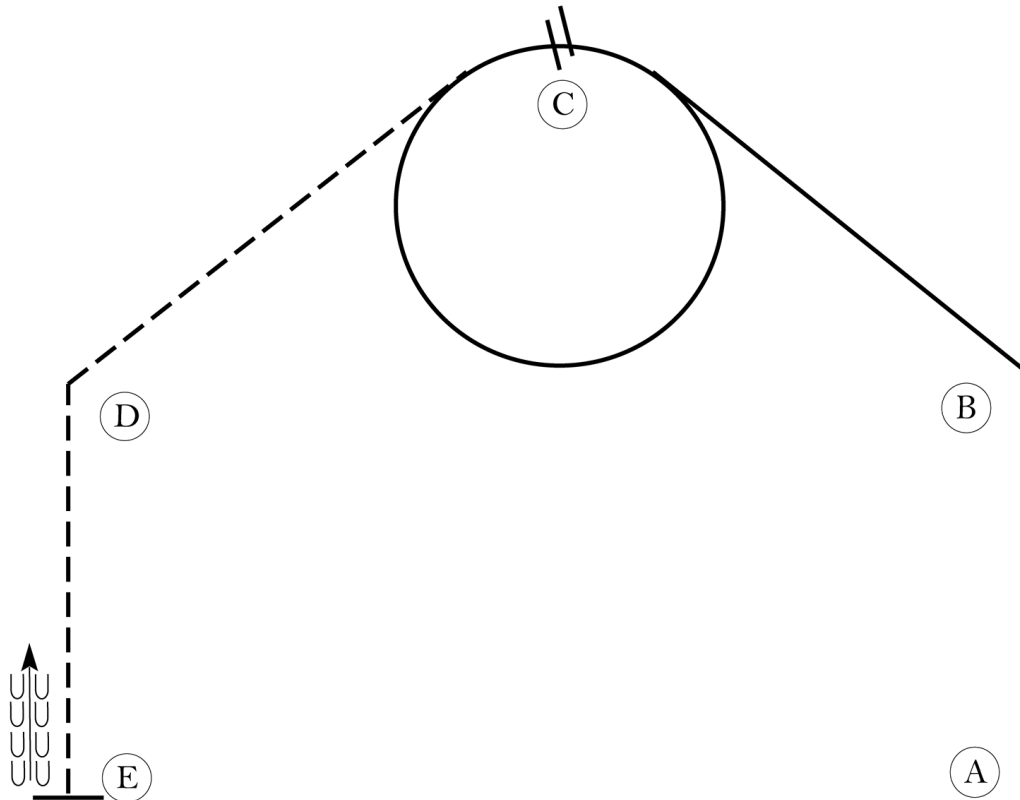

Be ready at A.

1. Walk approximately 2 horse lengths from A.
2. Trot on the right diagonal to B.
3. Canter on the right lead to C.
4. Perform a simple lead change at C.
5. Canter a circle on the left lead around C.
6. Sitting trot to D.
7. Trot on the left diagonal to E.
8. Halt at E and back approximately one horse length.

When dismissed, follow the instructions of your ring steward.

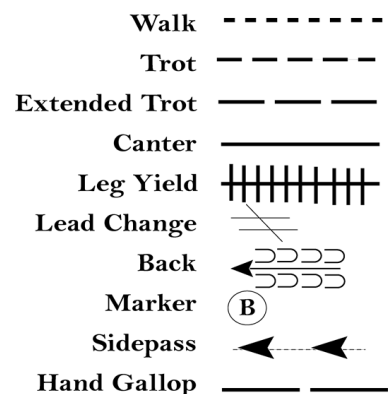

[HSE/2-37]

Pattern Provided by:

DQHA

Q 9

Hunt Seat Equitation Amateur 3/4

Show Date: 02. - 11.10.2009

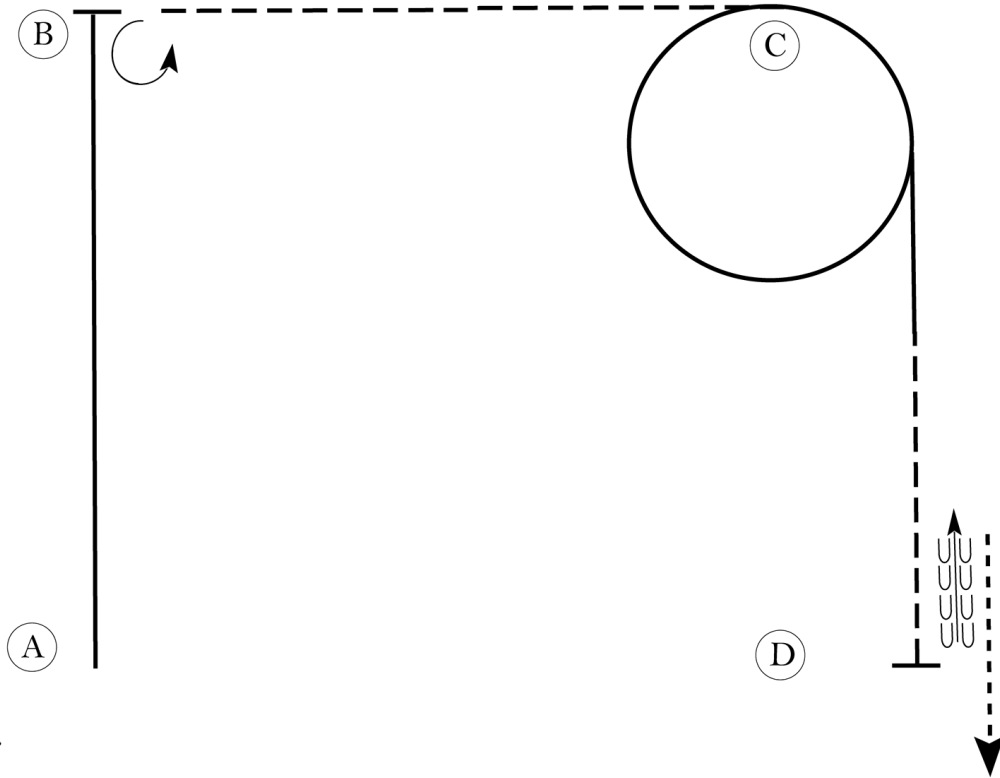

Be ready at A.

1. Canter on the left lead to B.
2. Stop at B and execute a 270 degree turn on the haunches to the left.
3. Posting trot on the right diagonal to C.
4. Canter on the right lead in a circle around C.
5. Continue on the right lead halfway to D.
6. Posting trot on the left diagonal to D.
7. Stop at D and back approximately one horse length.
8. Walk forward to and past D.

Follow the instructions of your ring steward.

Walk	-----
Trot	- - - - -
Extended Trot	— — — — —
Canter	—————
Leg Yield	
Lead Change	↙ ↘
Back	← ← ← ← ←
Marker	⊙
Sidepass	← — — — — →
Hand Gallop	— — — — —

[HSE/2-43]

Pattern Provided by:

DQHA

w w w . H o r s e S h o w P a t t e r n s . c o m

w w w . H o r s e S h o w P a t t e r n s . c o m

Q9

Showmanship at Halter Amateur 1/2

Show Date: 02. - 11.10.2009

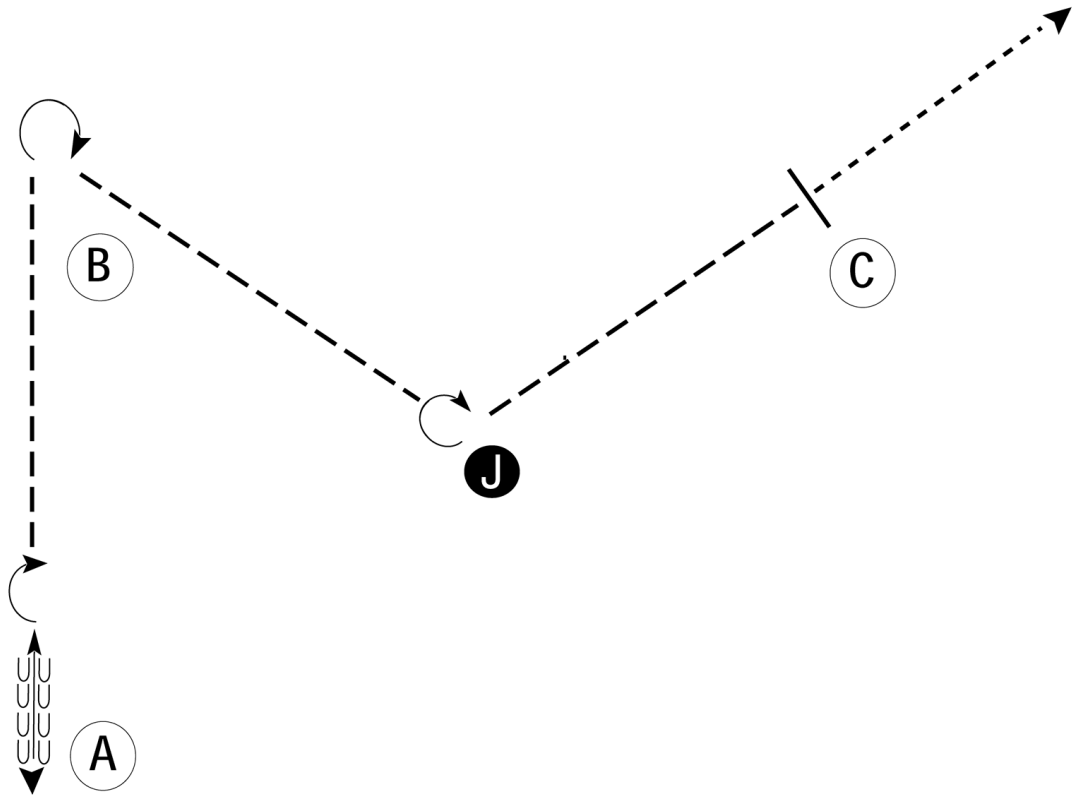

Be ready at A facing away from B.

1. Back one horse length from A.
2. Turn 180 degrees and trot past B.
3. Stop past B, turn 135 degrees and trot to judge.
4. Stop and set up for inspection.
5. When dismissed, do a 3/4 turn and trot to C.
6. Stop at C. When dismissed, walk straight away from C to exit.

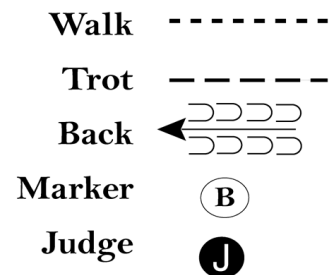

[S/2-24]

Pattern Provided by:

DQHA

Q9

Showmanship at Halter Amateur 3/4

Show Date: 02. - 11.10.2009

w w w . H o r s e S h o w P a t t e r n s . c o m

w w w . H o r s e S h o w P a t t e r n s . c o m

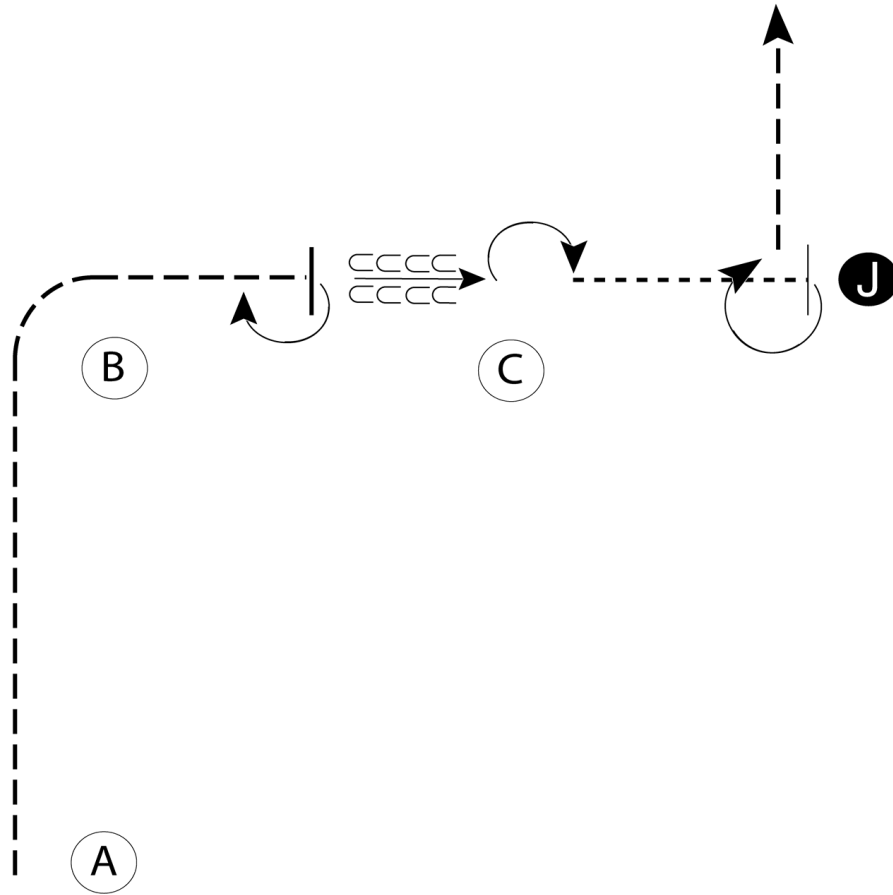

1. Jog from A around B
2. Half way to C stop and perform a 180 degree turn
3. Back to C
4. Perform a 180 degree turn, walk to Judge and set up for inspection
5. When dismissed perform a 270 degree turn and trot to lineup

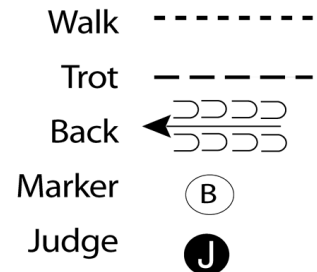

[S/2-26]

Pattern Provided by:

DQHA

Q 9

Hunt Seat Equitation Youth 3/4

Show Date: 02. - 11.10.2009

w w w . H o r s e S h o w P a t t e r n s . c o m

w w w . H o r s e S h o w P a t t e r n s . c o m

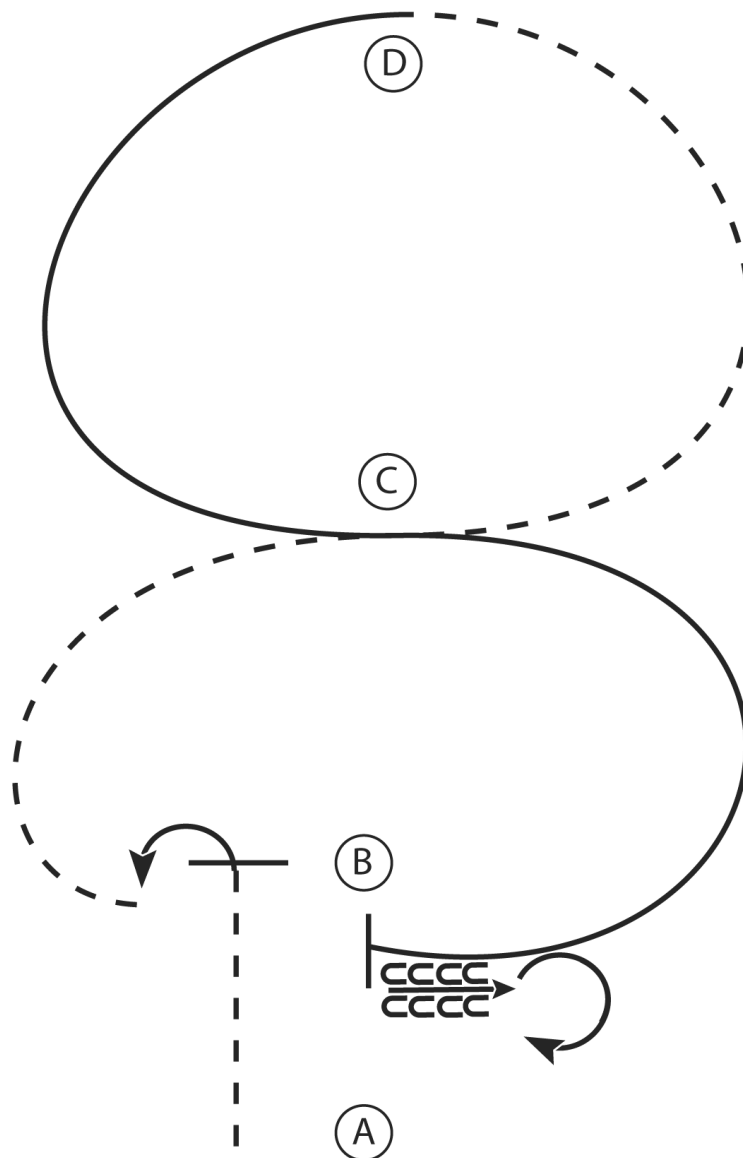

1. Sitting trot A to B
2. Stop at B and perform a 90 degree turn to the left on the forehand
3. Posting trot on the left diagonal in a half circle to C
4. At C change diagonals and posting trot a half circle to D
5. At D canter on the left lead in a half circle to C and continue in a half circle to B
6. Stop at B and back 4 steps
7. Perform a 270 degree turn to the right on the hindquarters

Walk
Trot	-----
Extended Trot	- - - - -
Canter	—————
Leg Yield	
Lead Change	↘ ↙
Back	←←←←← →→→→→
Marker	(B)
Sidepass	←-----→

[HSE/3-7]

Pattern Provided by:

DQHA

Q9

Showmanship at Halter Novice Youth

Show Date: 02. - 11.10.2009

w w w . H o r s e S h o w P a t t e r n s . c o m

w w w . H o r s e S h o w P a t t e r n s . c o m

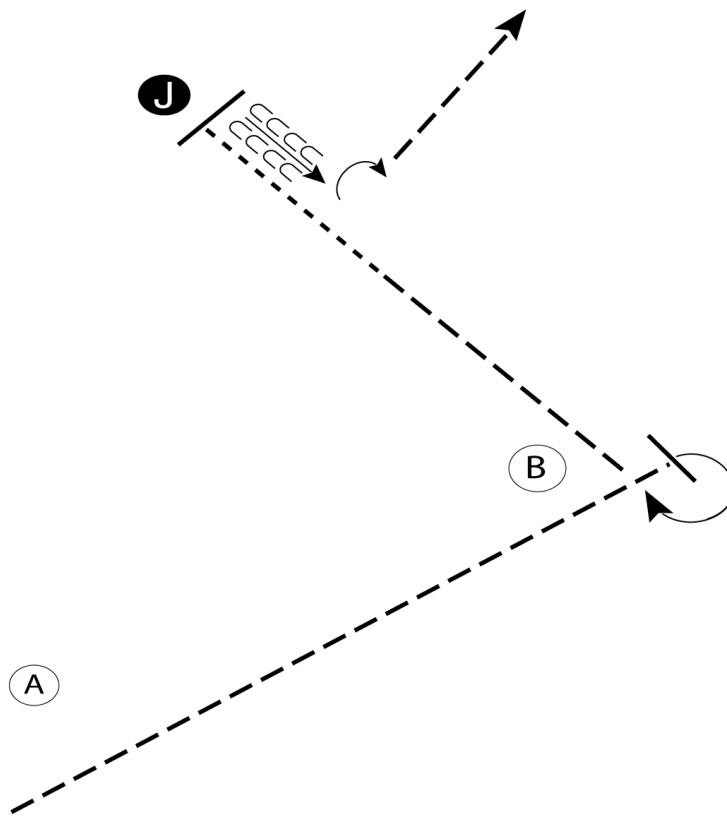

Be ready at A.

1. Trot past B and stop
 2. Perform a 270 degree turn
 3. Trot halfway to the Judge
 4. Break to the walk and walk to the Judge
 5. Stop and set up for inspection
 6. When dismissed back one horse length
 7. Perform a 90 degree turn and trot to the line-up
- Follow the instructions of your ring steward.

- Walk -----
- Trot _____
- Back ←═══
- Marker (B)
- Judge (J)

[S/1-27]

Pattern Provided by:

DQHA

Q 9

Showmanship at Halter Youth 1/2

Show Date: 02. - 11.10.2009

w w w . H o r s e S h o w P a t t e r n s . c o m

w w w . H o r s e S h o w P a t t e r n s . c o m

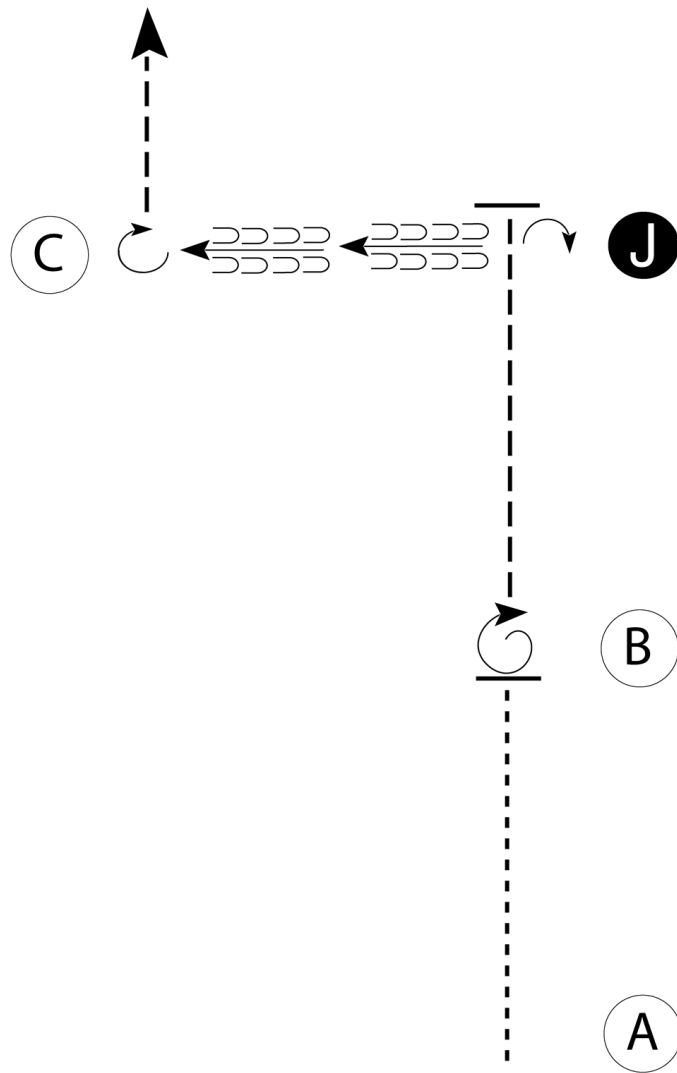

Be ready at A.

1. Walk A to B.
2. Stop at B and perform a 360 degree turn.
3. Trot until even with Judge.
4. Stop and perform a 90 degree turn; set up for inspection.
5. When dismissed, back to C.
6. Perform a 270 degree turn and trot straight away.

Walk -----
Trot -----
Back ← -----
Marker (B)
Judge (J)

Follow the instructions of your ring steward.

[S/2-4]

Pattern Provided by:
DQHA

Q 9

Showmanship at Halter Youth 3/4

Show Date: 02. - 11.10.2009

w w w . H o r s e S h o w P a t t e r n s . c o m

w w w . H o r s e S h o w P a t t e r n s . c o m

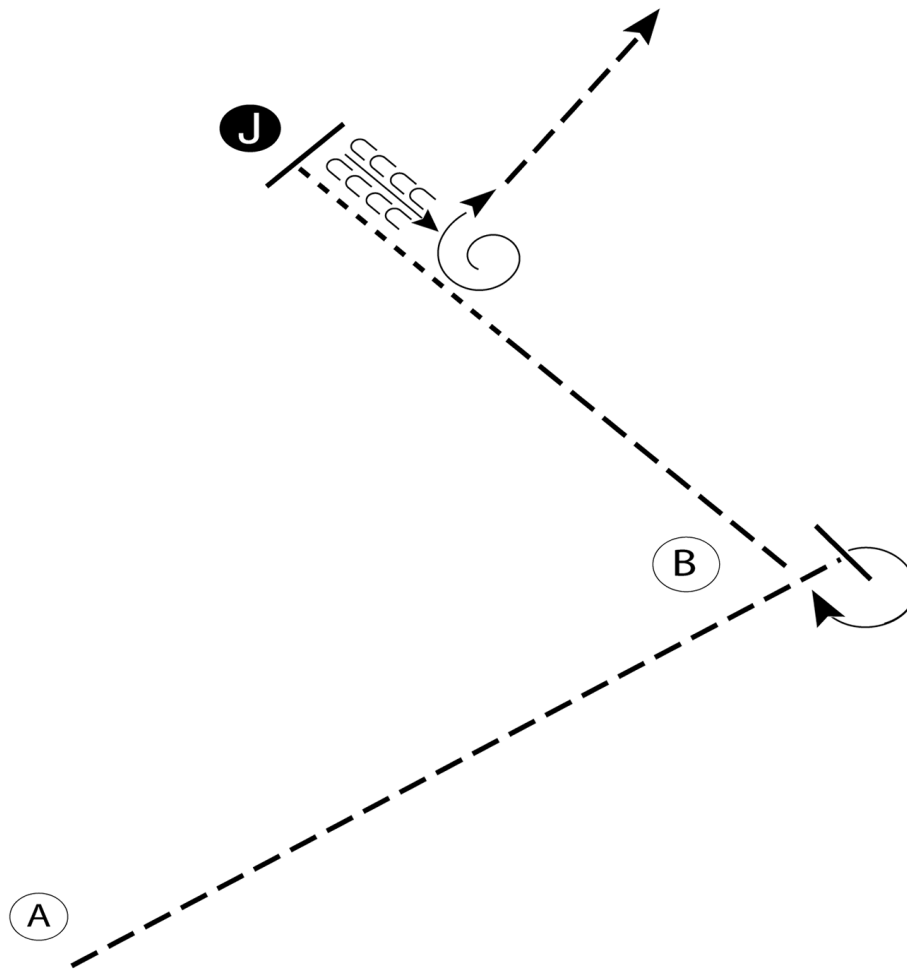

1. Begin at A. Trot past B and stop
2. Perform a 270 degree turn
3. Trot halfway to the Judge
4. Break to the walk and walk to the Judge
5. Stop and set up for inspection
6. When dismissed back one horse length
7. Perform a 450 degree turn and trot to the line-up

Walk	-----
Trot	- - - - -
Back	← ⊃ ⊃ ⊃ ⊃ ⊃ ⊃
Marker	⊙ B
Judge	● J

[S/2-27]

Pattern Provided by:

DQHA

Q 9

Western Horsemanship Youth 1/2

Show Date: 02. - 11.10.2009

www.HorseShowPatterns.com

www.HorseShowPatterns.com

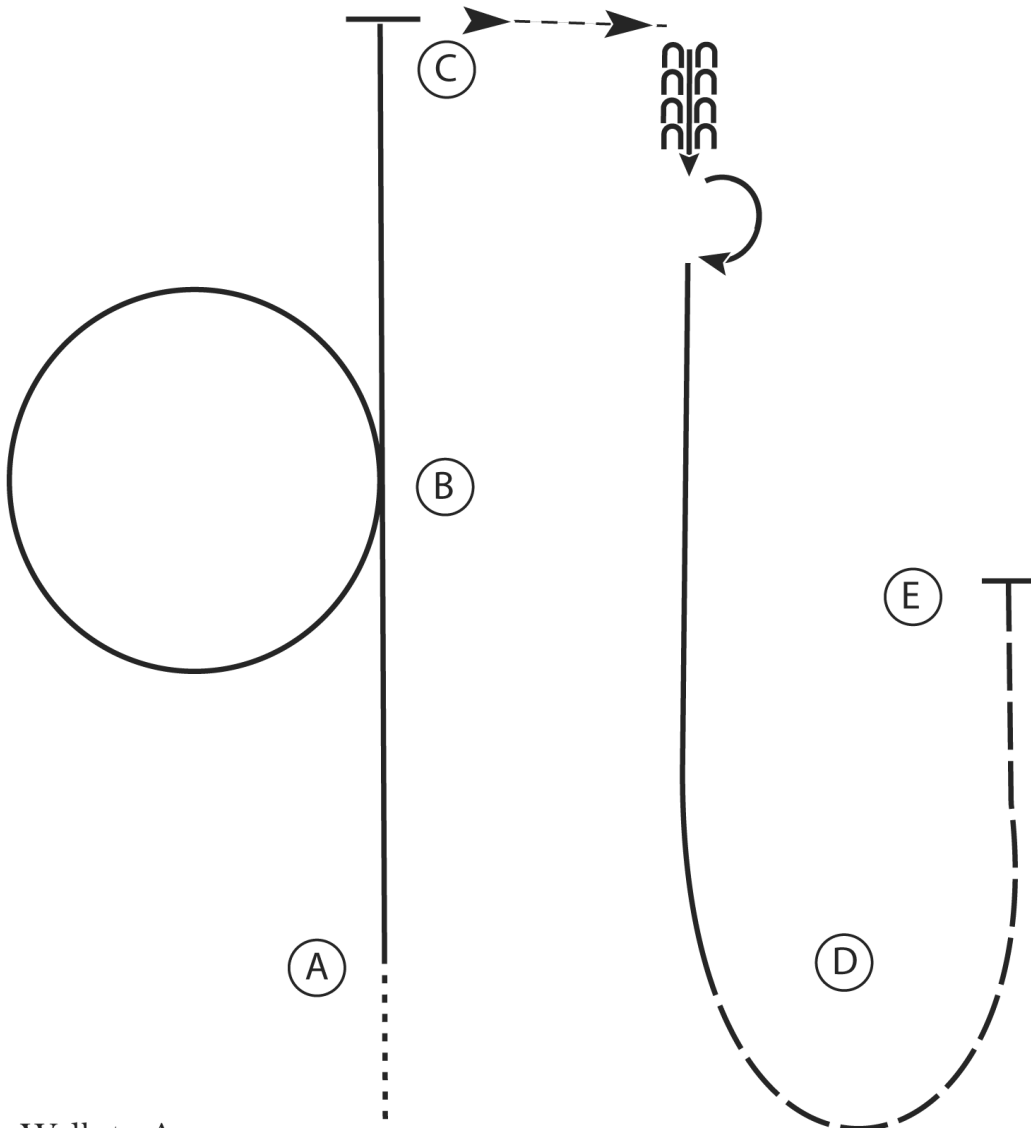

1. Walk to A
2. At A lope on the left lead to B
3. At B lope a circle to the left and continue to C
4. Stop past C and sidepass right
5. Back 3 steps
6. Perform a 180 degree turn to the right on the hindquarters
7. Lope on the right lead to D
8. At D extend the jog around D
9. Stop at E

Walk
Jog	-----
Extended Jog	-----
Lope	—————
Leg Yield	
Lead Change	⌘
Back	⌘
Marker	Ⓚ
Sidepass	⌘

[WH/3-26]

Pattern Provided by:

DQHA

Q 9

Western Horsemanship Youth 3/4

Show Date: 02. - 11.10.2009

w w w . H o r s e S h o w P a t t e r n s . c o m

w w w . H o r s e S h o w P a t t e r n s . c o m

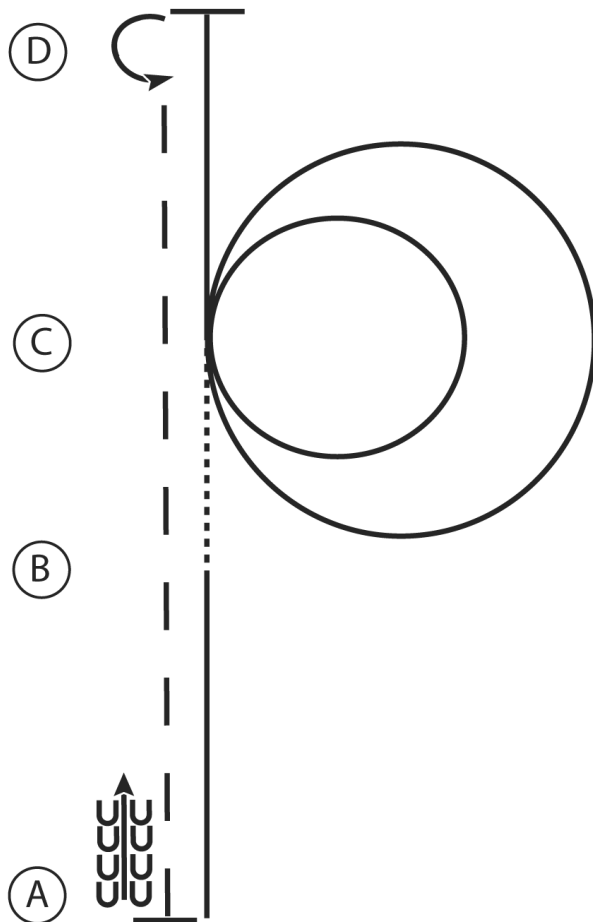

1. Lope on the left lead A to B
2. At B walk to C
3. At C lope a large fast circle to the right on the right lead followed by a small slow circle to the right on the right lead
4. Continue the lope to D
5. At D stop and perform a 180 degree turn to the left
6. Extend the jog to A
7. At A stop and back 4 steps

Walk
Jog	-----
Extended Jog	-----
Lope	—————
Leg Yield	
Lead Change	↙
Back	←←←←
Marker	(B)
Sidepass	←-----←

[WH/3-7]

Pattern Provided by:

DQHA

Q 9

Western Horsemanship Novice Youth

Show Date: 02. - 11.10.2009

1. Walk to A.
2. At A stop and back 3 steps.
3. Jog A to B.
4. Stop at B and perform a 360 degree turn to the right.
5. Jog a circle to the right around C.
6. At B lope on the left lead, lope a circle to the left around D.
7. Continue the lope to E.
8. Stop at E.

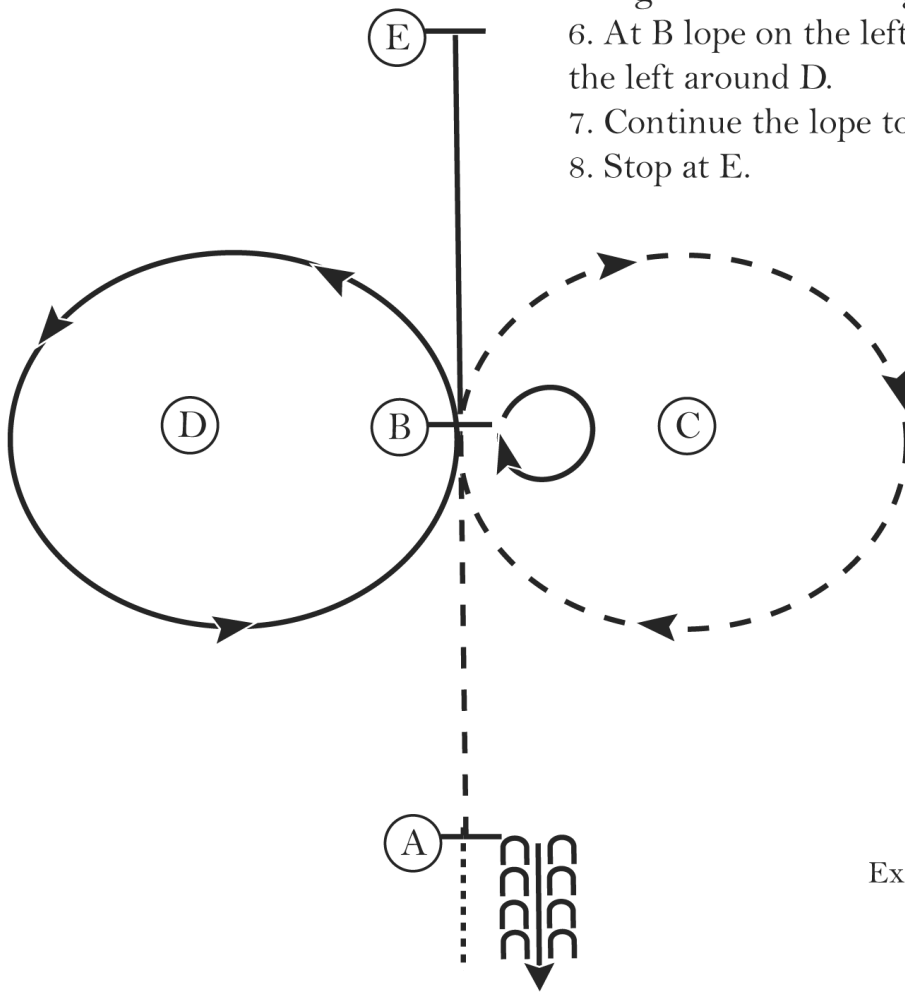

Walk
Jog	-----
Extended Jog	- - - - -
Lope	—————
Leg Yield	
Lead Change	///
Back	←←←←← →→→→→
Marker	(B)
Sidepass	←-----→

[WH/1-16]

Pattern Provided by:

DQHA